

EXPLODED DRAWING AND PARTS LIST

GAS CONCRETE NAILER

MODEL: GSN50-30

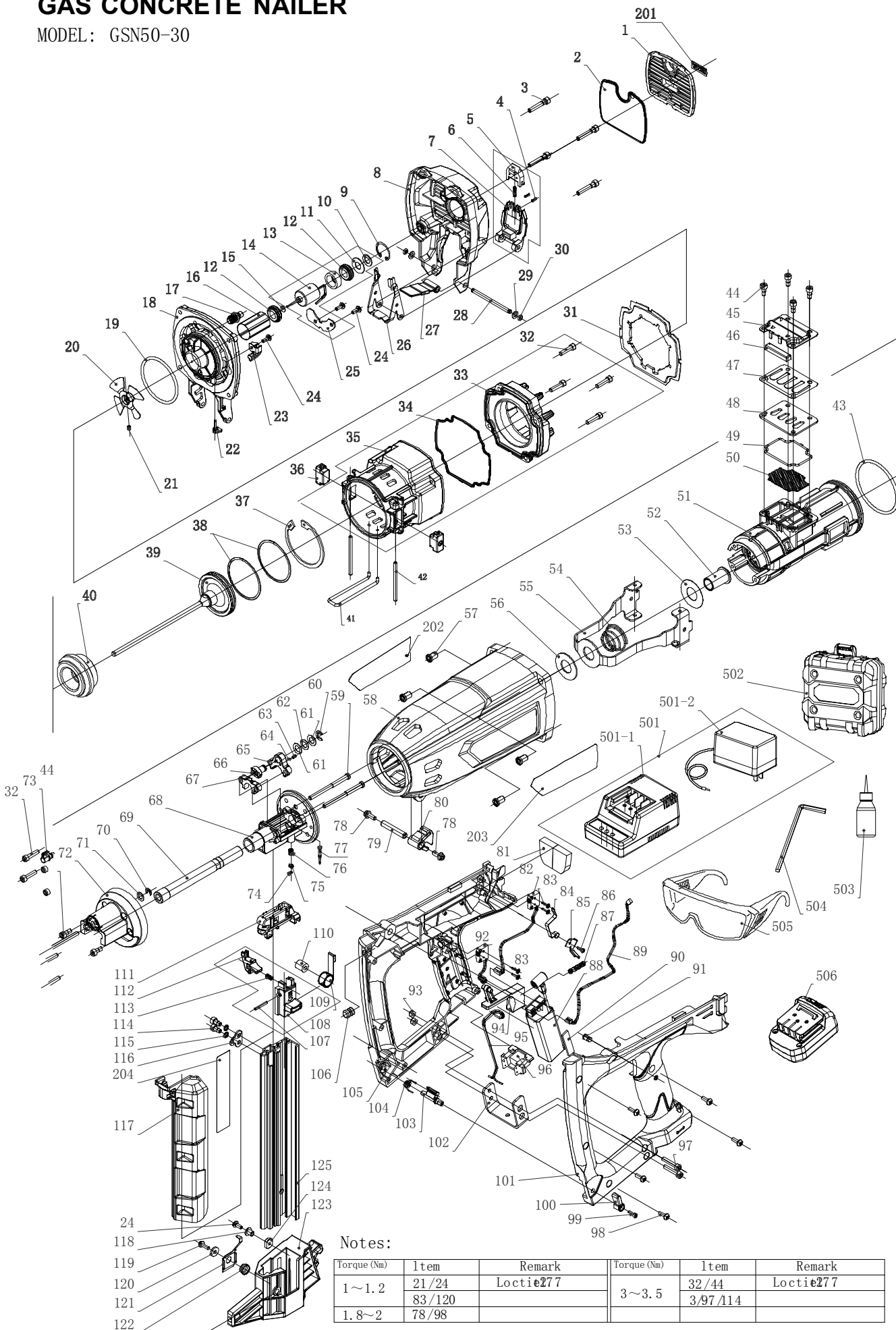

Notes:

Torque (Nm)	Item	Remark	Torque (Nm)	Item	Remark
1~1.2	21/24	Loctite277	3~3.5	32/44	Loctite277
1.8~2	83/120			3/97/114	
	78/98				

PART LIST GSN50-30

No.	Parts Name	Qty
1	Top Cover	1
2	Filter	1
3	Hex.Socket HD M5×30	4
4	Spring Straining Pin 2×8	2
5	Latch	1
6	Latch Spring	1
7	Cell Cover	1
8	Filter Cover	1
9	Retaining Ring d0=24	1
10	motor line protecting	1
11	Gasket	1
12	Rubber Gasket	2
13	Washer	1
14	Motor,	1
15	dustproof plate	1
16	Mount Sleeve	1
17	Spark Plug	1
18	Cylinder Head	1
19	O-Ring, Ø59.92×d3.53	1
20	Wind leaf component	1
21	Holding Screw M4×5	1
22	Adapter	1
23	Lead frame	1
24	Cross Recessed Bolt M4×10	4
25	Motor PCB Board Assembly	1
26	Cell Lever	1
27	Cell Rubber	1
28	Shaft	1
29	Washer d=5	2
30	O- Retaining Ring 3.5×2	2
31	Chamber clapboard	1
32	Hex.Socket HD M5×20	8
33	Chamber Head	1
34	Abnormity O-Ring	1
35	Chamber	1
36	positioning block	2
37	Retaining Ring d0=62	1
38	Piston Ring 60X0.8	2
39	Piston Assembly	1
40	Piston Bumper	1
41	Lock Bar	1
42	Parallel pin ,Ø4×60	2
43	O-Ring 70×3.53	1
44	Hex.Socket HD M5×12	6
45	Buffer Cover	1
46	Muffler	1
47	Lead Valve	1
48	Read Plate	1
49	Abnormity O-Ring	1
50	Exhaust Baffle	1
51	Cylinder	1
52	guide sleeve	1
53	Spring washer,0.5mm	1
54	Pushing Arm Spring	1
55	Pushing Arm	1
56	Cell Cover ,1.5mm	1
57	Nut M5	4
58	Housing	1
59	Guide Bar	2
60	bead flange , Ø7	1
61	Cell Cover , 0.5mm	2
62	Cell Cover , Ø8 ,0.3mm	1
63	Ball spring	1
64	Steel ball , Ø3	1
65	depth adjustment block	1
66	depth adjustment	1
67	Barrel sleeve	1
68	Nail Seat	1
69	Nailer Mouth	1

Note: ☆ said Wearing parts

No.	Parts Name	Qty
70	bead flange , Ø5	1
71	depth adjustment shim	1
72	Protect Cover	1
73	depth adjustment knob	1
74	Shaft collar, Ø4	1
75	Lock set	1
76	Latch spring	1
77	nail groove lock pin	1
78	Hex Bolt M5×10	2
79	Rotating shaft	1
80	Lock block	1
81	Fuel cell sponge	1
82	Fan switch assembly	1
83	Screw ST2.2×11	4
84	Switch spring	1
85	Wiring cover	1
86	Screw ST2.9×8	1
87	Trigger spring	1
88	Controller Assembly,7.2VDC	1
89	Mehradrer Plug Assembly	1
90	Fixed sponge	1
91	LED Light	1
92	Ignition switch assembly	1
93	Locknut M5	2
94	Trigger	1
95	Power line component	1
96	handle bracket.	1
97	Hex.Socket HD M5×25	2
98	Countersunk Screw ST4.2×20	5
99	Hex.Socket HD. M3x8	1
100	nail groove locking knob	1
101	Left Handle	1
102	Hook	1
103	nail groove locking block	1
104	nail groove lock spring	1
105	Right Handle	1
106	nail groove rubber column	1
107	Parallel Pins 3×20	1
108	Nail Feeder Seat	1
109	Ribbon Spring	1
110	Ribbon Spring shaft	1
111	Nail groove fixed frame	1
112	Nail Feeder	1
113	Nail Feeder Spring	1
114	Hex.Socket HD M5×10	2
115	elastic washer, M5	2
116	nail groove plate	1
117	nail groove dust plate	1
118	nail groove spacer sleeve	1
119	Screw ST4.2×8	1
120	Washer d=4	1
121	Catch	1
122	Catch Spring	11
123	Fixed Block	1
124	Nail groove nut	1
125	Nail Magazine	1
201	Top Name Plate	1
202	Specification Plate	1
203	Name Plate	1
204	Warning label	1
501	Charger components	1
501-1	Charger Base	1
501-2	Adapter	1
502	Case Assembly	1
503	Oiler	1
504	Hex.Bar Wrench M5	2
505	Safety Glasses	1
506	Battery Pack	2

